

Danfoss | Plate and shell heat exchanger

Maximum performance with compact welded heat exchangers

SONDEX® SPS plate and shell heat exchangers are the perfect solution for high pressure and high temperature applications thanks to their fully welded plate packs. The leak-proof construction makes them a great fit for steam heating and condensing applications, as well as handling aggressive media on the plate side.

The SONDEX® SPS heat exchangers offer a small footprint and great thermal performance that exceeds the capabilities of shell and tube heat exchangers.

Capable of handling
high temperatures
and pressure up to

40 bar

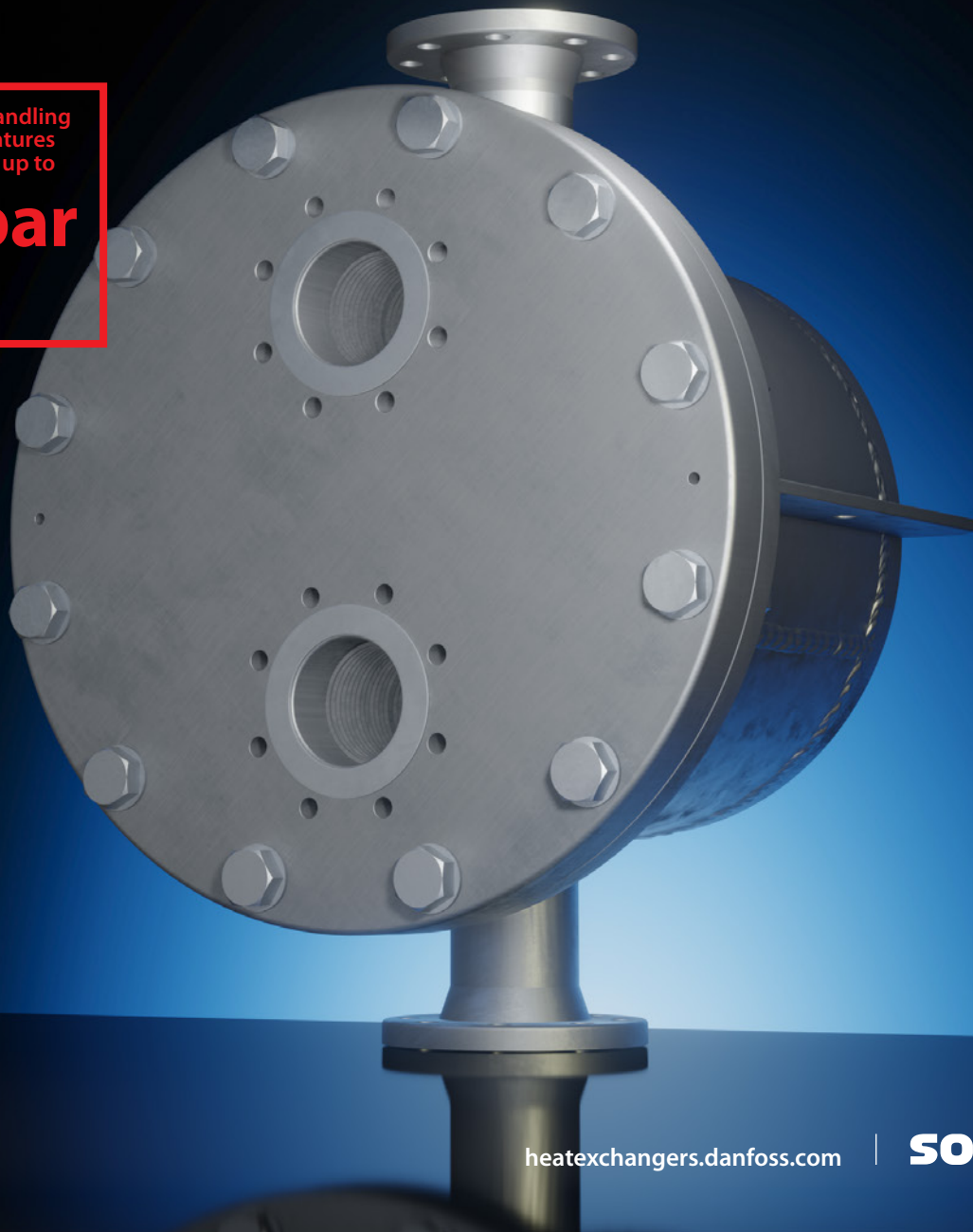

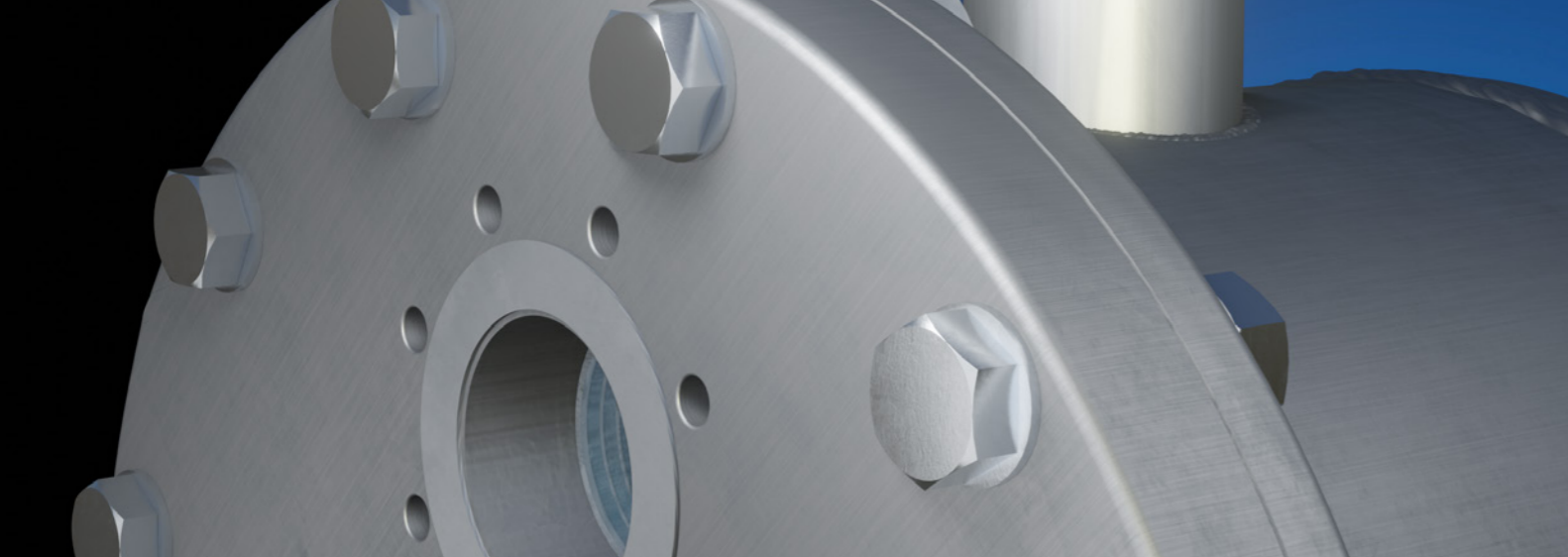

Rising to the challenge

The fully welded plate pack is the core of the SPS design that makes this product range a go-to choice for handling high pressure, high temperatures, and aggressive media. Much less space demanding and notably lighter in weight, they are perfect replacements for shell and tube heat exchangers, with the added benefit of considerably higher heat transfer capabilities.

Combined strengths

The SONDEX® SPS plate and shell heat exchanger range combine the strengths of shell and tube heat exchangers and plate heat exchangers, retaining the high working pressure and temperatures of the former coupled with the very high efficiency of the latter.

A “best of both worlds” solution, our plate and shell heat exchangers provide unmatched performance for a wide range of duties and applications - even with most challenging and aggressive media.

Suitable media and processes



Typical/common industries

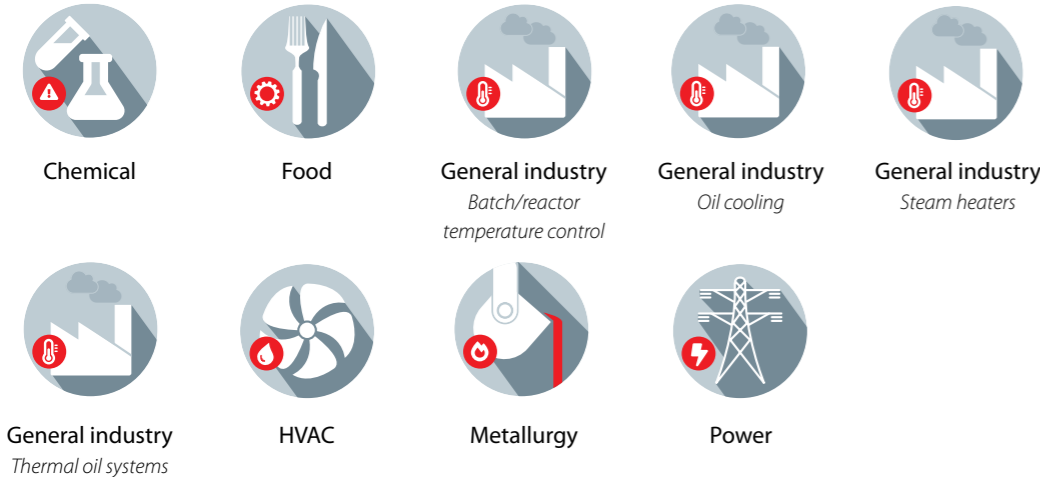

Constructed for challenging applications

- Safe operation with aggressive media, high temperatures, and high pressure
- Robot-precision ensures uniform, high-quality laser welding of the plate pack
- Fully welded plate pack without gaskets

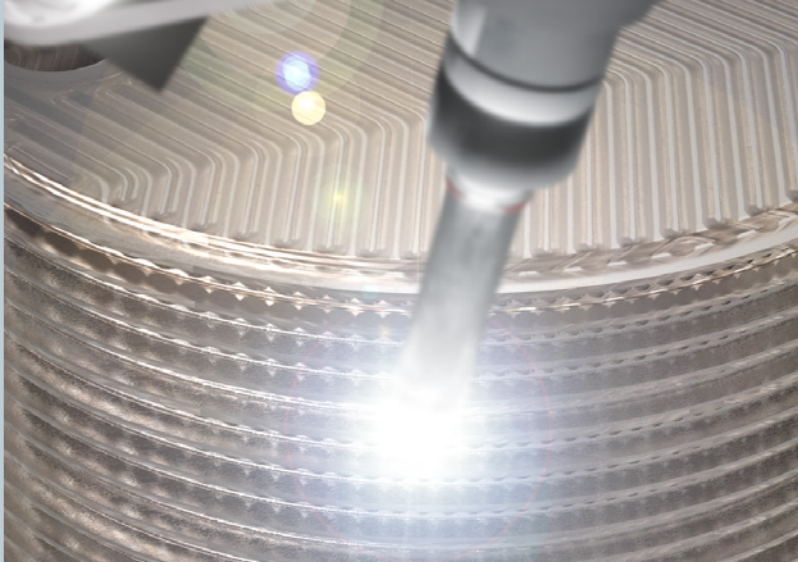

Reliable high-performance operation

- Fishbone plate technology enables our plate and shell heat exchangers to provide much higher K-value than traditional shell and tube units
- Being highly resistant to thermal shocks, as well as thermal and pressure fatigue, they are very well-suited for cyclic duties

Wide plate portfolio

- Large selection of plate and connection sizes for any duty and application ensures optimal solutions
- Asymmetric plate channel design available for applications with large differences in flow or viscosity

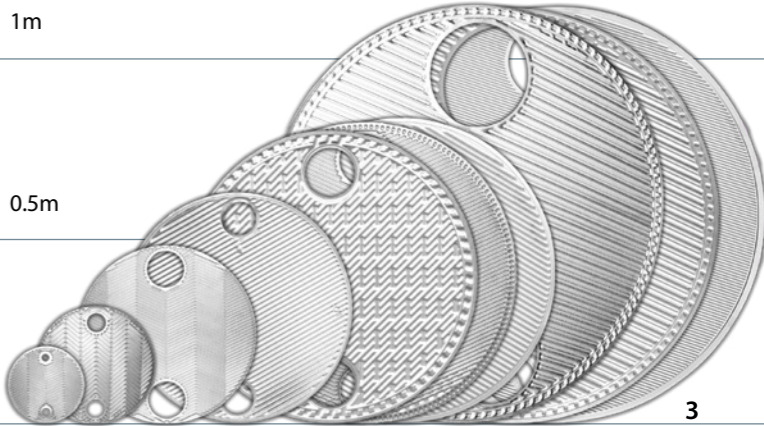

Heat transfer specialists through and through

At Danfoss, we have specialized in the development and manufacturing of heat exchangers. We do all our own tooling and have our own hydraulic presses in-house for our plate production. This closed-loop production makes it easier to control and monitor the quality.

Developing optimized solutions is a core value of our design philosophy and we use our deep application knowledge and input from customers to create second-to-none heat exchanger solutions.

We can configure our heat exchangers to match the exact requirements of your application, thanks to our extensive plate range. This allows us to deliver a powerful solution that provides reliable, unmatched heat transfer while lowering the energy consumption of your connected systems.



Deep application knowledge

- We use our deep application knowledge to configure each heat transfer solution and match the exact requirements of your application and systems
- We take your data into account when we dimension the heat exchanger to optimize your solution for maximum efficiency and energy utilization



Versatile product portfolio

- We have developed a very versatile product portfolio in close cooperation with our customers, offering solutions for any application
- We have different plate designs for different duties to ensure optimal heat transfer in all solutions

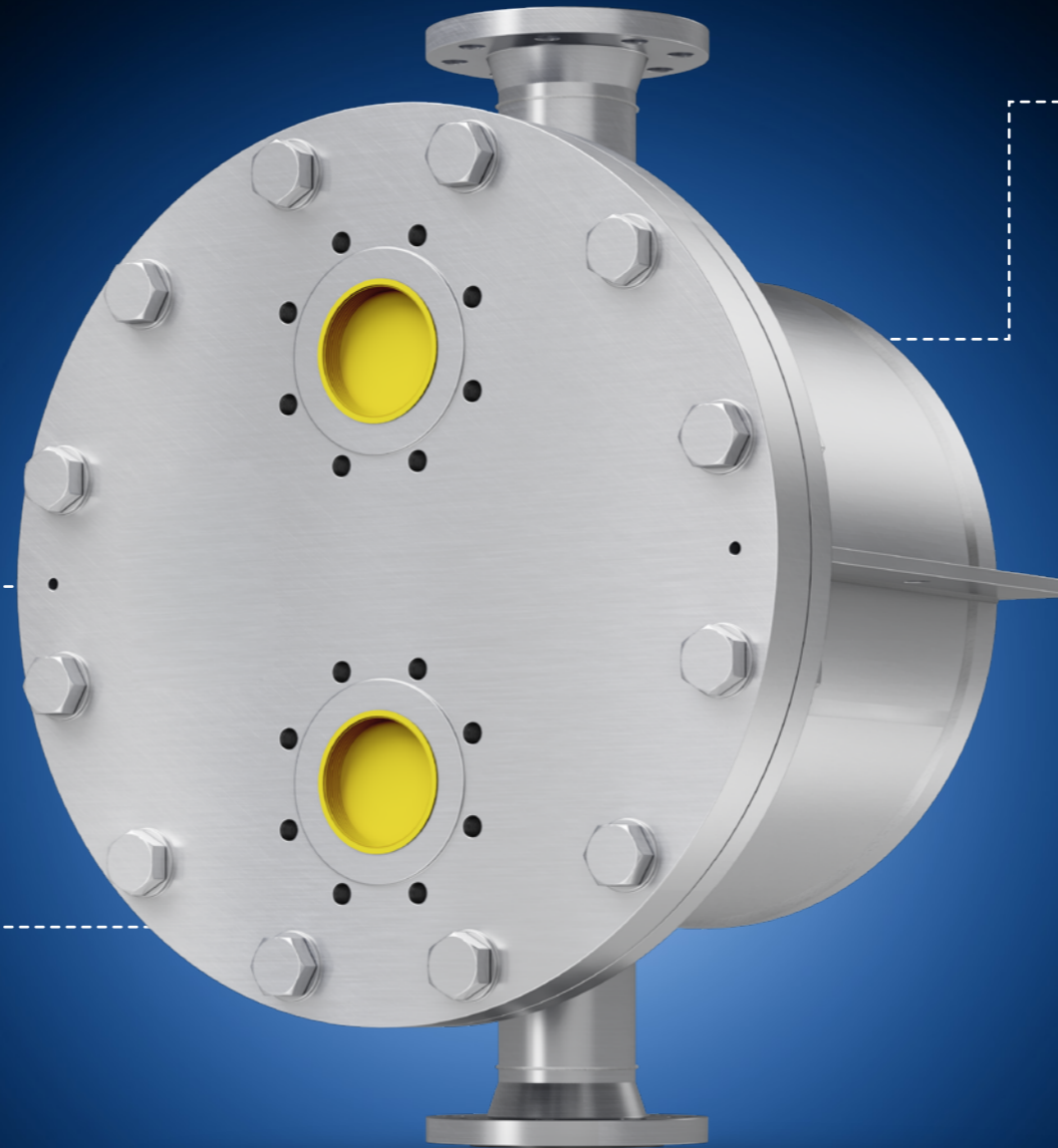

The most efficient heat transfer

- Plate technology provides a high heat transfer coefficient that reduces the needed surface area
- Perfected flow distribution and corrugated plate patterns are key in generating the optimal turbulent flow
- Proven thermal performance



Sturdy construction and high quality

- Automated laser cutting and welding with robot-precision produces consistently high quality
- Safe operation with low internal media volume and minimal risk of leakage
- Exit-control to ensure only high quality products reach our customers

Technical overview

SPS Type	SPS22	SPS 72	SPS 179	SPS 400	SPS 646	SPS 647	SPS 648	SPS 1200	SPS 1201	SPS 1203
Max. working pressure	Bolted: 25 bar by default (360 psi) / fully welded: 40 bar by default (850 psi)									
Max. operating temperature	Bolted: 250 °C (482 °F) / fully welded: 400 °C (582 °F)									
Min. operating temperature	-10 °C (14 °F)									
Plate side connection, DN	25 (1")	50 (2")	100 (4")	100 (4")	150 (6")	150 (6")	150 (6")	300 (12")	400/150 (16"/6")	300 (12")
Shell side connection, DN	25-50 (1"-2")	50-100 (2"-4")	50-200 (2"-8")	65-250 (3"-10")	100-250 (4"-10")	100-250 (4"-10")	100-250 (4"-10")	100-300 (4"-12")	100-300 (4"-12")	100-300 (4"-12")
Plate material	Stainless steel EN 1.4404 (AISI 316L), Stainless steel EN 1.4401 (AISI 304L), Titanium. Other materials available on request.									
Shell material	Carbon Steel P355GH, Stainless steel EN 1.4404 (AISI 316L), Stainless steel EN 1.4401 (AISI 304L). Other materials available on request.									
Sealing material for bolted models	PTFE, Graphite. Other materials available on request									
Frame painting specification	Painting available for corrosion categories C2L, C4M, C5M									
Design standards	PED, ASME, TR TS. Other approvals available on request									
Number of passes	Up to 5									

Working principle

Learn more about the working principle of SONDEX® SPS heat exchangers. Click the button or scan the QR-code to watch the video on YouTube.



Design overview

1. Shell
2. Front cover
3. Back cover
4. Plate pack with flow distributors
5. Supporting wing

6. Shell-side connections
7. Plate-side connections
8. Housing flange for FL (bolted) models
9. Bolts for FL (bolted) models

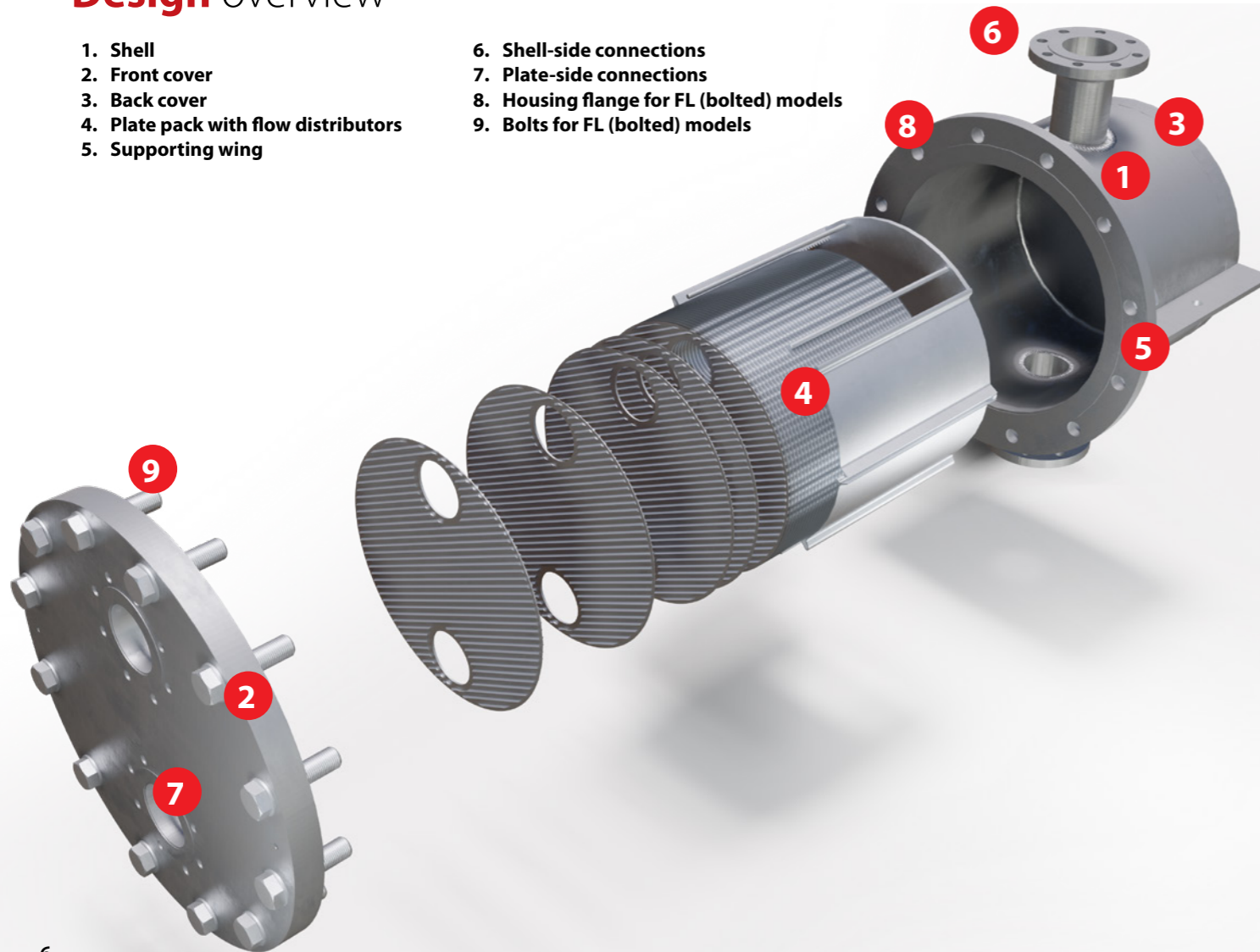

SONDEX® - a quality heat exchanger brand from Danfoss

Sondex and Danfoss join forces

In July 2016, Danfoss acquired full ownership of Sondex. This step marked the merger of two strong players creating an even more powerful and agile heat exchanger partner.

Transition into a product brand

In 2018, Sondex became SONDEX® - a quality heat exchanger brand of Danfoss. Customers can now benefit from one-stop shopping and the powerful infrastructure of Danfoss, as well as the heat transfer expertise of SONDEX®.

Value throughout the entire project



Product selection

Optimized for your application

Installation and commissioning

Product lifetime

After-sales service

Danfoss is with you every step of the way - from selecting the right product for you, to after-sales service.

A partnership based on extensive application knowledge

Working with Danfoss means more. It means that you do not only get highly reliable, efficient, and innovative solutions – you also get a partner that is a world-leading supplier in a wide range of applications.

Our partnership gives you access to a wide range of benefits. From extensive application knowledge to a wide range of solutions and tools.

Do you want to discover more?

Visit heatexchangers.danfoss.com to learn more about our heat exchanger solutions.

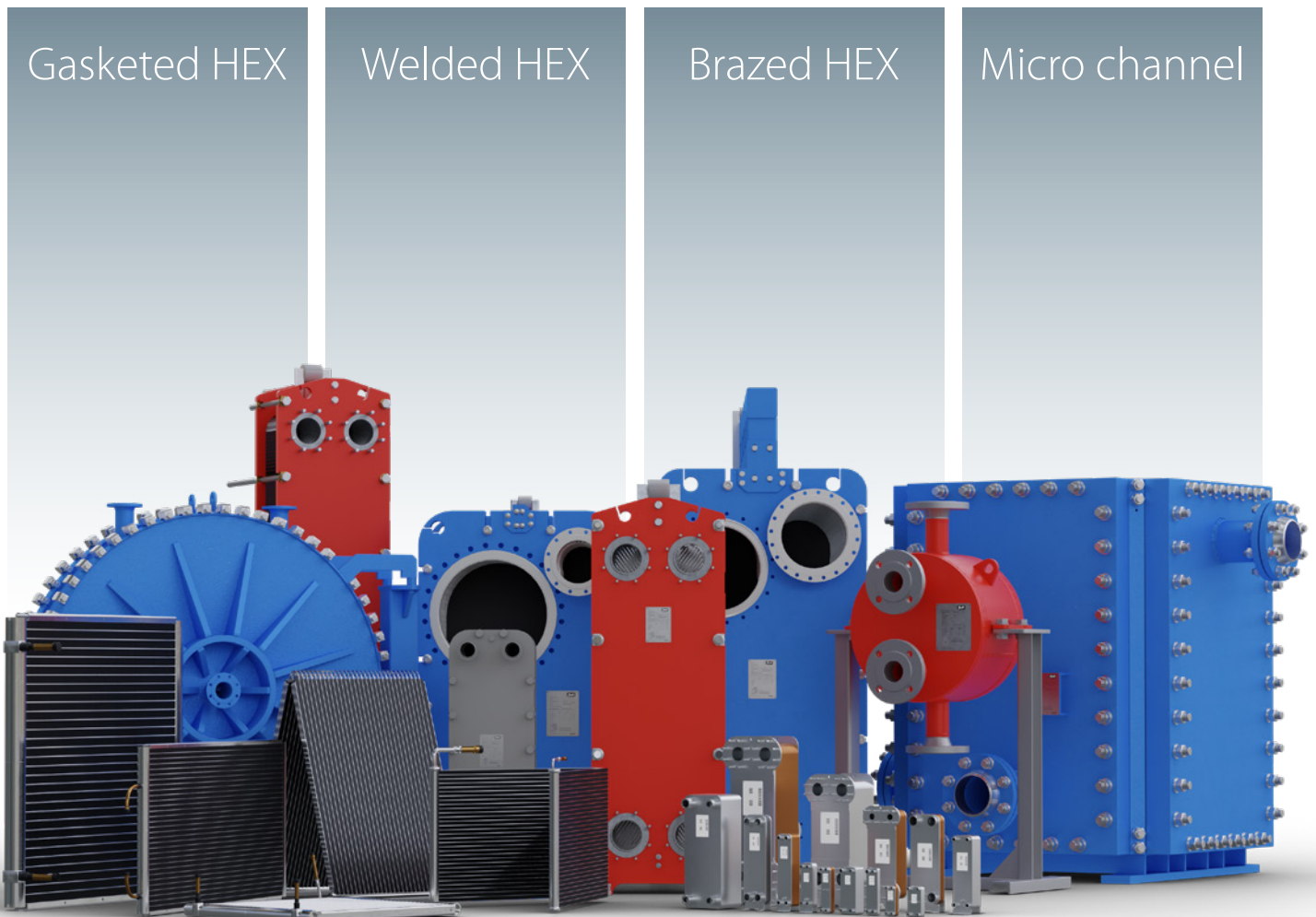

Danfoss A/S
Climate Solutions • Heat Exchangers • danfoss.com • heatexchangers.danfoss.com • +45 7488 2222

Any information, including, but not limited to information on selection of product, its application or use, product design, weight, dimensions, capacity or any other technical data in product manuals, catalogues descriptions, advertisements, etc. and whether made available in writing, orally, electronically, online or via download, shall be considered informative, and is only binding if and to the extent, explicit reference is made in a quotation or order confirmation. Danfoss cannot accept any responsibility for possible errors in catalogues, brochures, videos and other material. Danfoss reserves the right to alter its products without notice. This also applies to products ordered but not delivered provided that such alterations can be made without changes to form, fit or function of the product. All trademarks in this material are property of Danfoss A/S or Danfoss group companies. Danfoss and the Danfoss logo are trademarks of Danfoss A/S. All rights reserved.